

INNOVATION AUTOMATION

ALLMATIC

*The way to automated
workpiece clamping*

ALLMATIC
Spannsysteme **JAKOB**

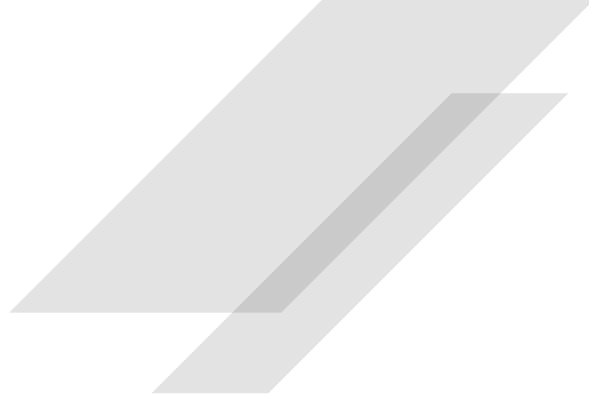

COMPETENCE

QUALITY

PRECISION

FLEXIBILITY

THIS IS WHAT ALLMATIC STANDS FOR



THE LEAP INTO THE FUTURE

Automation and Industry 4.0

There is a lot to be said in favour of automated production: it is faster, more precise and more cost-effective. The conditions for an automated increase in productivity are precision and clamping speed. The workpieces must be fixed in the machine tools as fast as possible and with

great force. The continual repetition of these clamping processes must be carried out with exactly the same force. This is exactly what the ALLMATIC clamping systems provide.

Automation solutions from ALLMATIC



TOMBSTONES

Tombstones for horizontal machining

The new tombstones portfolio offers choices such as a wide variety of spindle and jaw combinations.

This allows raw parts to be machined with the GRIPP technology and pre-machined workpieces with different clamping widths. Up to two parts per side can be clamped, you decide the number and arrangement of the clamping sides individually.

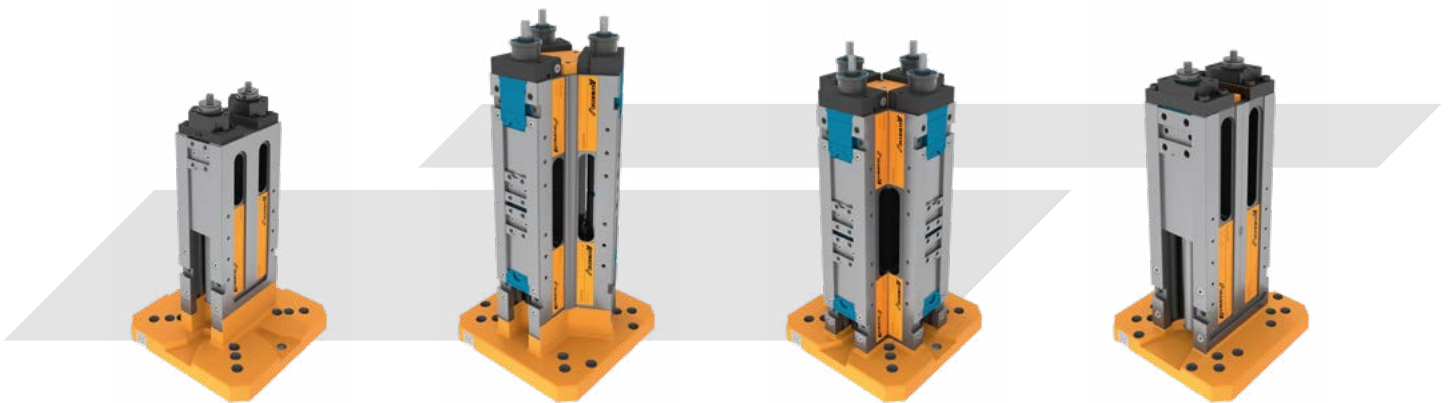

Tombstone - 57 variations: Available quickly with the configurator

The market for tombstones was confusing and difficult to understand up until now. With a new, modular product range and a sophisticated configurator, you can find the suitable system for you in less than 10 minutes.

The new configurator navigates you through the „product jungle“ in just three steps. You simply define your requirements and receive a qualified recommendation from a new, modular product range of 57 available variants in total. With 3D data and technical information, you can ensure that the tombstone fits your workpiece and machining center. Finding a suitable tombstone has never been so easy!



To Tombstone-configurator:
www.allmatic.de/tombstone

Tombstones at a glance

- 57 standard variants
- Configurable in just 3 steps
- Delivery time only 3 weeks
- Clamp 2 to 8 workpieces
- For unmachined parts and pre-machined workpieces

Product features at a glance

Positioning & Fixing

- Centering hole Ø50 H6, mounting holes for grid 40/50/63/125 mm
- Recording of zero-point clamping systems with bolt Ø25 H6



9 different spindles & numerous jaws

For clamping unmachined parts (with Gripp technology) and pre-machined workpieces with different clamping range and jaw widths.

You can clamp 1 or 2 workpieces per side..

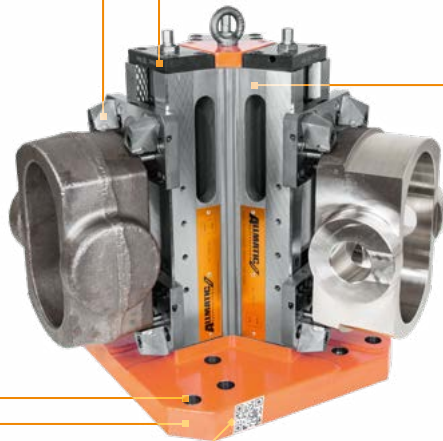
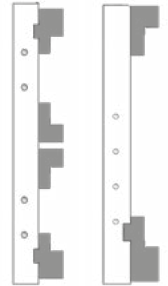

Number and arrangement of the clamping sides

2 × 180°



3 × 120°

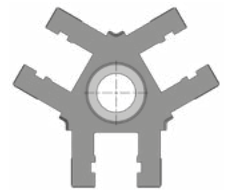

4 × 90°

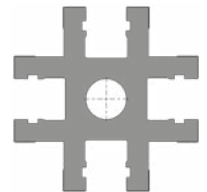

Base plate

Available in heights 45 mm and 110 mm (one in 74 mm)

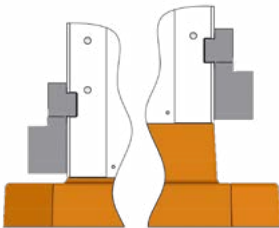

QR-Code with service data

Technical information and 3D data on exactly your tombstone can be found 24/7 for free download in the ALLMATIC service app.

If you register within 30 days, you can extend the statutory warranty of 2 years to a 4-year manufacturer guarantee.



Individual solutions

In addition to the standard products, ALLMATIC offers a variety of individual solutions. Each special solution can be individually adapted to your machine, your workpiece and your machining techniques. To be even more flexible, we manufacture clamping jaws adapted to the geometry of your workpieces.

WORKBUDDY

Ergonomic operation of tombstones



Fixation at machine or set-up station

Standard modules for customization

The installation of the WorkBuddy is based on two standard guiding arms, which are adaptable to the individual situation in your production. We are happy to support you with the installation!

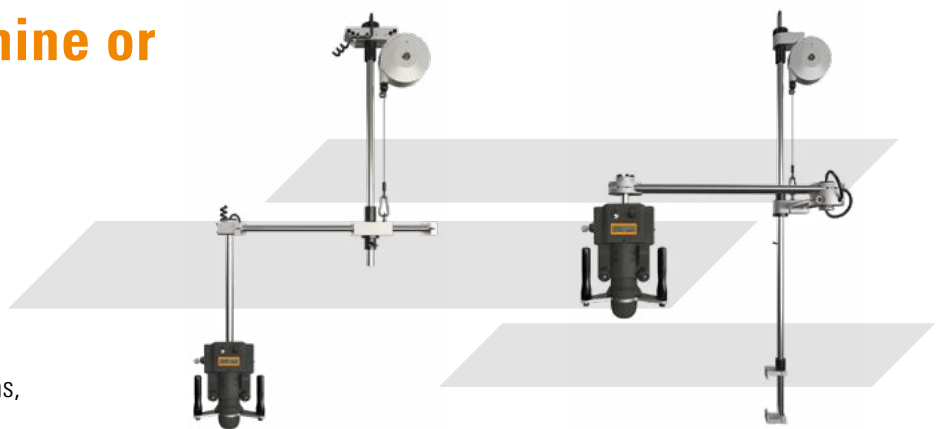

Guiding arm (top)
Z500 R620 L1200

Guiding arm (side)
Z780 R400-600

can be mounted left and right

WorkBuddy – Your assistance in mechanical clamping

We expand our tombstone portfolio with the WorkBuddy clamping aid for safe, ergonomic and efficient set-up

Set-up time plays an important role in production: expensive milling machines have to be rapidly retooled and workpieces clamped for processing to minimise downtimes. The clamping of workpieces is key in this process – and what we specialises in.

We have now added the WorkBuddy to our clamping system of tombstones.

The electronic clamping aid speeds up the loading of tombstones during work preparation and enables ergonomic work that is gentle on the joints.

Unwieldy torque wrenches and incorrect tightening torques are in the past.



Clamping systems are among the most important machine elements for machining centres: a CNC machine can only work quickly and efficiently if workpieces are securely fitted and support the machining process. The fast and reliable clamping of workpieces is essential to ensuring that cost-intensive machine tools are economically efficient. Clamping is generally done using a torque wrench or hand crank inside the machine itself or at an external set-up station.

One major disadvantage of this method is the awkward handling – often above head height. This results in physical strain and a loss of working hours, which puts a financial burden on companies.

We have now found a convincing solution for these kind of clamping processes in work preparation (WP): the WorkBuddy.

Your advantages

- For ergonomic, joint-friendly operation of tombstones
- Reduction of operating errors results in safer processes
- Quick opening and clamping process (v= 10 mm/s)
- Individual installation at the machine or set-up station

Sample calculation for lost time injuries

Monthly salary of machine operator	3.000 €
Employer costs for the employee	4.000 €

Continuation of payment in case of illness	6 Weeks
--	---------

Costs for the company due to absence from work 6.000 €

(without machine downtime or other additional costs)

CLAMPDRIVE

Your electric alternative to hydraulic clamping

Higher production flexibility even with market fluctuation - thanks to agile automation and unmanned setup change: ALLMATIC was looking for an automation solution that not only combined pallet and workpiece handling in one system, but also the unmanned setup change of a machine.

Advantages of the ALLMATIC automation solution:

- It offers attractive jobs for qualified employees, as a one-shift operation with one employee and unmanned production the rest of the time means machines running 24/7.
- A plus in productivity and flexibility. Processes and workflows are optimised by integrating previously manual work processes into the automation.
- It secures jobs. At full capacity, the machine runs unmanned in 2 ghost shifts; in case of a reduction in orders, there is no need to react with job cuts.

Automation of workpiece handling

- Plug and Play: Fast installation thanks to PROFIBUS interface; other interfaces are possible
- Expensive hydraulic solutions
Clever alternative to
 - no hydraulic rotary union required in the machine table
 - simple integration of tombstones in the production process, as there is no need for hydraulic solutions
- Easy retrofitting for existing machining centres and installation for new plans with and without pallet changer
- Higher productivity and flexibility
→ 24/7 with 2 ghost shifts
- Avoid unsafe clamping: with the ClampDrive the workpiece is always securely gripped when opening and closing the vice.
- Use of various tombstones through the 2-axis handling system.
- A wide variety of clamping systems can be used by simple programming.
- All modular systems can be controlled with the ClampDrive.
Two versions:
 - to 50 Nm
 - to 150 Nm



Your advantages

- All modular clamping systems can be controlled with the ClampDrive
- 50 Nm all ergonomic spindles from ALLMATIC
- 150 Nm for products from other manufacturers
- Safe clamping due to double control
- Automated opening or clamping process
- Individual installation on the machining centre

Product features at a glance

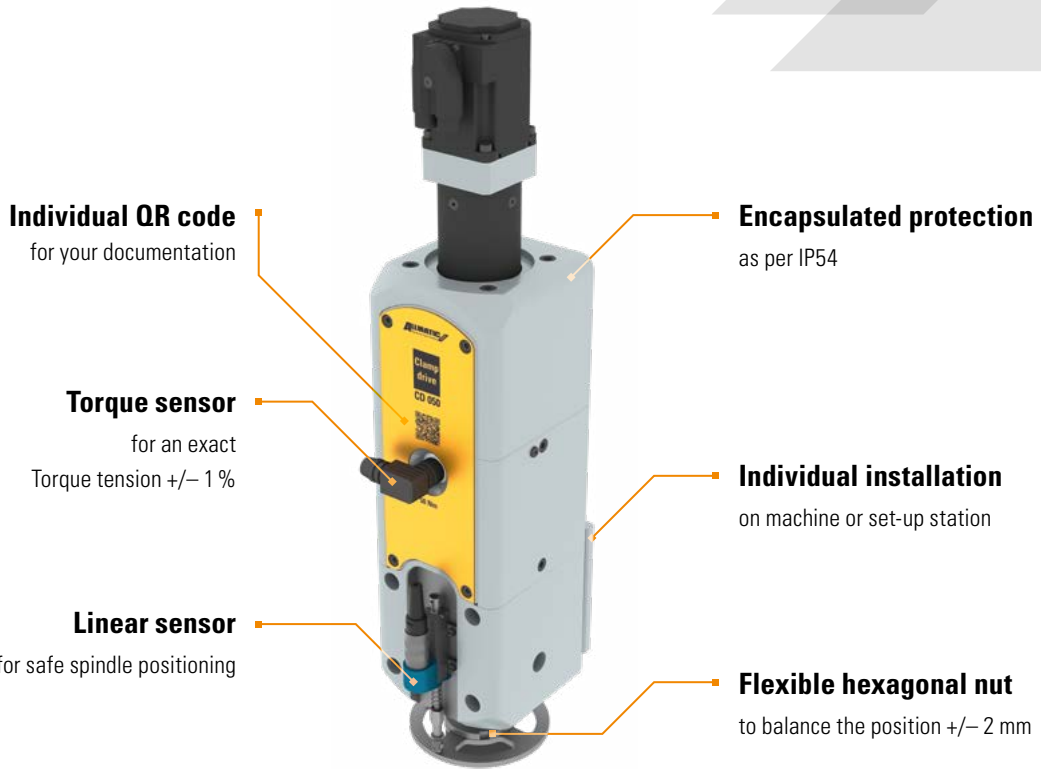

Suitable for
all spindles of the
TITAN 2-/LC-/TC-/NC8-
and DUO-Serie (wrench size 14)
and other clamping systems
available on the market

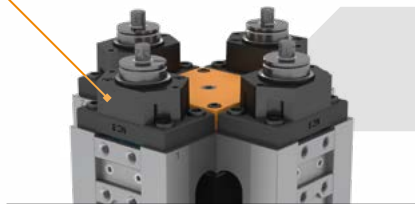

CLAMPDRIVE – BEST PRACTICE

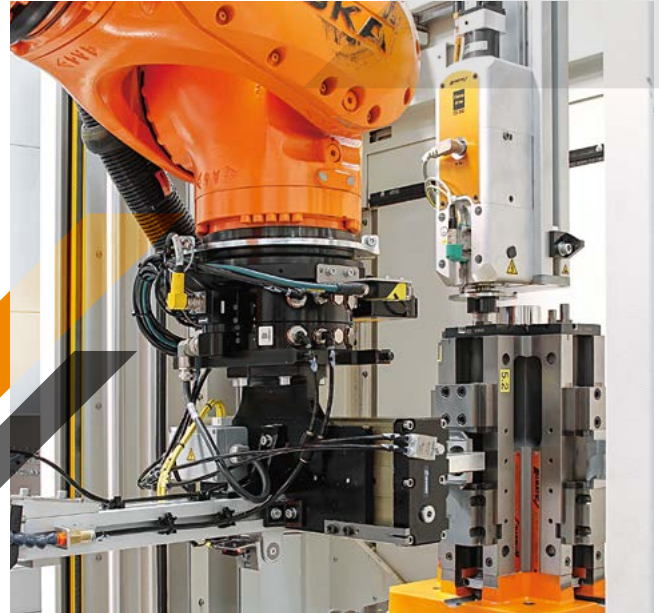

All-in-One-automation, including setup change

Agile robot cell for handling workpieces and pallets

It was possibly one of the most ambitious automation projects at ALLMATIC-Jakob Spannsysteme so far, something that was probably unheard-of and unique, namely creating a robot cell.

ALLMATIC-Jakob has set itself the goal of becoming the „technology leader in the clamping systems segment“ by 2030. In the best interest of our customers, we need to continuously develop innovative products, add more intelligent solutions and, above all, intensely focus on automation.

In that regard, one of our most ambitious projects was the development and realization of a robot cell that is automated to make up to 32 different components for vices in individual batches of more than 100 units per order around the clock. That doesn't just combine the handling of pallets and workpieces within one system, but also the unattended set-up changeover of the machine.



See the ClampDrive in action here.

Are you interested in seeing the ClampDrive live in our production?

We will be happy to explain the ClampDrive to you on site. Please feel free to contact us.

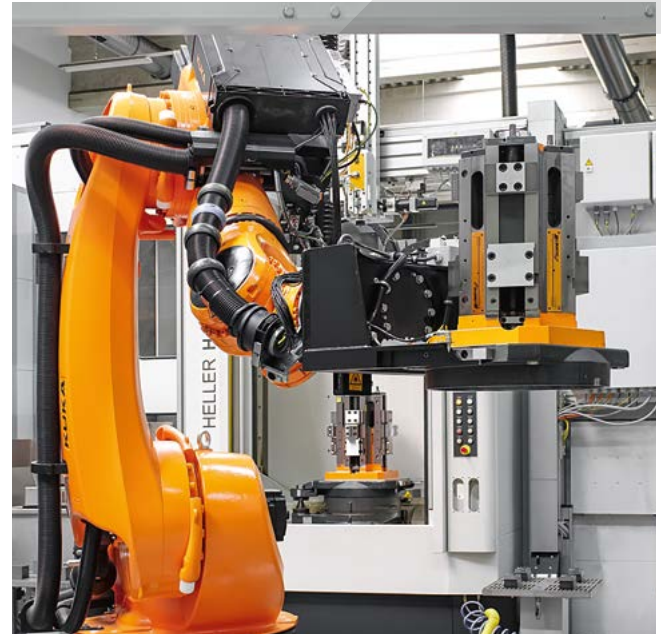

Rethinking and gaining valuable insights

Using this automated system, ALLMATIC has not only scored in productivity and flexibility in the manufacturing process, but according to Luis Paiba (head of development and design) and Herbert Mayr (CEO) – it has also gained valuable insights.

„All parts that are now produced with the robot cell were previously made by us already. As a result of the automation, we had to change our way of thinking and thus we were able to identify new potential to optimize our processes and procedures. As an example, workpieces can now be completely machined

using 2 instead of 3 clamping steps. We have adapted our workpieces for this purpose. We also added previously manual work processes to the automation by integrating a blowing and anti-rust coating station into the cell,” says Luis Paiba.

„Automation secures jobs since we can now respond significantly better to order fluctuations. At the moment, our robot cell runs at a capacity of 90 percent, producing 32 different components unmanned in 2 ghost shifts.

If the number of incoming orders were to go down dramatically, we would not automatically be

forced to cut jobs since the robot cell could be run in just 1 unattended shift.

We save about €150,000 a year in labour costs by having two ghost shifts.”

Herbert Mayr
CEO of ALLMATIC



CENTROLITE

CentroLite - the small centric vice from AllLite

AllLite is the digital business unit of ALLMATIC-Jakob Spannsysteme GmbH founded in 2017.

With a fully automated production line, AllLite provides outstanding quality made in Bavaria quickly and available for purchase online.

CentroLite is the first centric vice that has all the essential functions, without unnecessary, cost-driving features. The production of the modularly designed centric vices is carried out on demand with a high degree of automation, the distribution is largely online. AllLite achieves this performance with optimized designs and manufacturing processes

that comply with industry standard 4.0. AllLite is focusing its offering on demand, particularly from the one-off and small batch production sectors, as well as from companies with market-leading automation solutions. It is precisely these selected functions that the CentroLite clamping systems from AllLite fulfil with pinpoint accuracy and at

a reasonable price. Without compromising on performance - the Gripp solution, for example, achieves a clamping force of 28 kN, an excellent value. In addition, the vise is also suitable for 5-axis machining (also available with consoles).

Product features

1. CentroLite 68K

- Clamping width with gripper jaws: 0-103 mm
- Clamping width with step jaws: 0-104 mm
- Weight: max. 4,2 kg

2. CentroLite 68M

- Clamping width with gripper jaws: 0-163 mm
- Clamping width with step jaws: 0-164 mm
- Weight: max. 5,7 kg



CentroLite is compatible with the following zero-point clamping systems:

- GRESSEL gredoc
- Schunk VERO-S
- Lang Quick Point 52×52
- System 3R MacroMagnum
- Hilma Quintus 60
- Roemheld
- Matzak
- Erowa
- AMF

CentroLite covers the most common zero-point clamping systems.

Features

Jaws:

- All surfaces hardened
- High side and step side with thread for attaching e.g. step strips
- V notch for clamping round workpieces

Gripper jaws:

- For pre-milled parts up to 1000 N/mm²
- For raw materials up to 550 N/mm²
- Parallelism < 0,3 mm



Gripper jaws b67
with integrated gripper row



Step jaws b67
smooth



Gripper jaws reduced-width b38
with integrated gripper row



Step jaws reduced-width b38
smooth



Floating jaw b67
with integrated gripper row or smooth



CLAMP ASSIST BLE

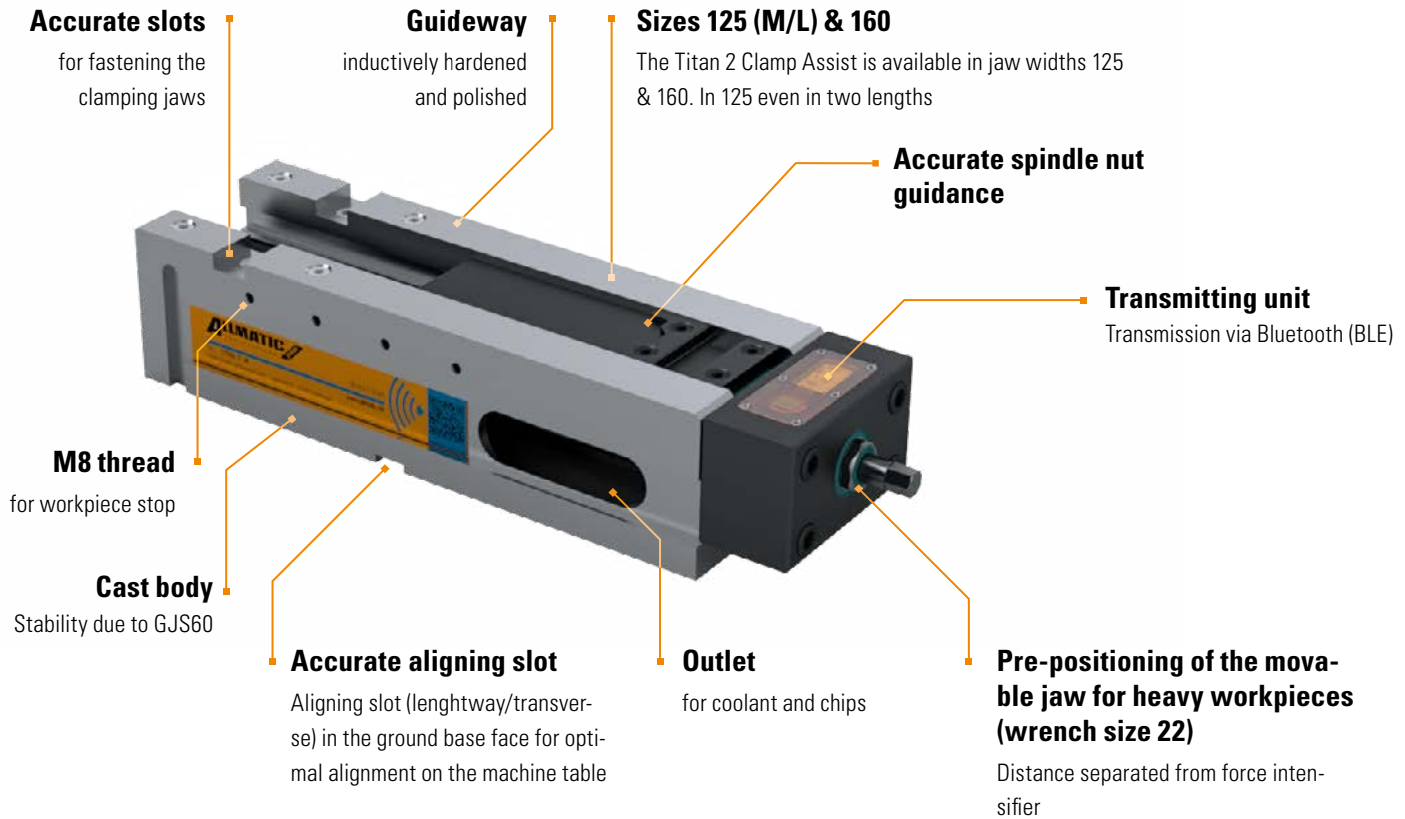

Features

- The service life of the replaceable batteries of the transmitter unit is given by efficient energy management up to 6 months (two shift operation)
- Firmware update possible
- Operating temperature between 10° C and 40° C
- Protection class of the spindle type IP65
- Transmission range up to 20 m - depending on ambient conditions

Function

- Recording of the current clamping forces in the fully enclosed high-pressure spindle by means of an integrated, electronic measuring system and transmission to the Bluetooth industrial receiver (BLE)
- Recording independent of clamping jaws, as the measuring system is integrated in the spindle
- Clamping force is constantly monitored in the clamped state
- Force values are transmitted with the standard Bluetooth protocol (from BLE 4.2)
- The clamping force preset by the user (reference force) is indicated by an LED light at the BLE when 90 % is reached

Clamp Assist BLE – Clamping force sensing directly on the workpiece

Automatic clamping force monitoring

Permanent precision through constant clamping force is an important factor in series production. Increase safety during milling and optimise your production line.

With the Clamp Assist you monitor the clamping force directly in the spindle and ensure secure clamping - with high repeatability throughout the entire machining process.



Receiving unit

Monitor up to 8 spindles at the same time



Terminal



AUTOCLAMP

The automated clamping system...

AutoClamp is a technology study and the next step, to further develop clamping technology towards of Industry 4.0.

The aim is to replace the manual clamping process with an electro-mechanical drive. This intends to simplify the work of your employees, enable automatic loading and unloading and provide additional safety.

Area of application

- For 3- and 4-axis machines
- Optimal for partially and fully automated systems
- To check the clamping before starting machining

Product features

- Electronic, four-stage force setting for safe operation
- Opening width of the clamping jaws of 4,5 mm for inserting a new workpiece
- Automatic signal when the clamping force is reached
- Energy efficiency (power only needed during clamping process; 24 V/40 A)
- Safety due to self-locking voltage even in the event of a power failure

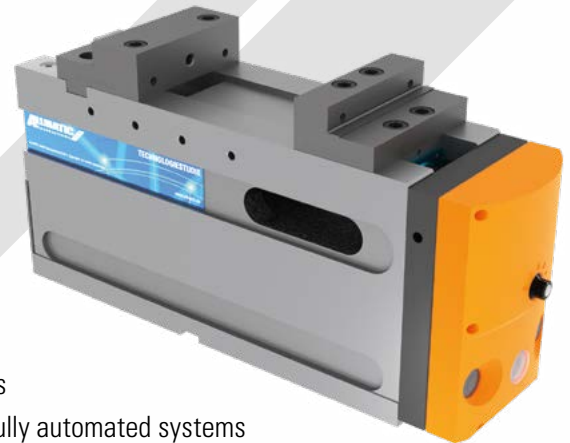

... for unusual manufacturing processes

DRÄXLMAIER and FEF developed the friction welding technology, ALLMATIC supports with a world first in the range of clamping technology.

The automotive supplier Dräxlmaier uses the vices with purely electric drive to produce friction-welded connections on aluminium conductors.

The friction welding process has the potential to establish itself as economically interesting and significantly weight-saving even from a short cable length.

The E-vice ensures the optimum process sequence with high adjustable clamping force and speed and, at the same time, has a greater power stroke for an optimized process flow. Via the integrated clamping force monitor, conclusions can be drawn with regard to the quality of the inserted components and the crimp process; it also precludes welding mistakes right from the start.



OUR PROFIL AND OUR MISSION

The world's best clamping systems

For 45 years we have offered our customers machine vices which are easy to operate and ergonomic.

Our vices hold the workpieces tight and thus avoid damage to humans and machines. The reliability and precision reduce machine downtimes, allowances, waste and thus costs. The purchase price is also amortized by the very long lifetime.

We are the only vice manufacturer to guarantee a 20-year supply of spare parts and probably offer the fastest service. In the future, our vices will become even more accessible and intelligent. They communicate with their environment and relieve the strain on your employees even more.

ALLMATIC
Spannsysteme JAKOB



„Our aim is to become the worldwide technological leader in the area of machine vices.

In addition, we are continuously working in the processes – such as production, assembly, support, sales, service and administration to stay ahead. A stable, long-term development with a secure profit situation takes priority over growth in turnover and short-term achievement of profits.“

Herbert Mayr
CEO from ALLMATIC

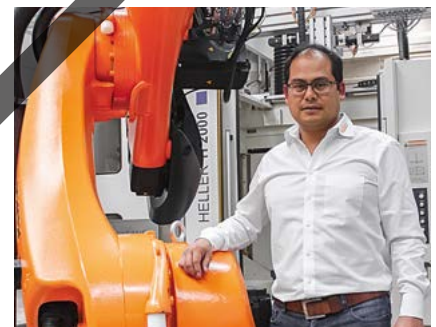



COMPACT
EASY
EFFICIENT

THIS IS WHAT ALLMATIC REPRESENTS





www.allmatic.de

ALLMATIC-Jakob Spannsysteme GmbH

Jägermühle 10
87647 Unterthingau

+49 8377 929-0
sales@allmatic.de